

PC917X/PC918X

High Speed, High CMR OPIC Photocoupler

■ Features

1. High speed response
(t_{PHL} : TYP. $0.3 \mu s$ at $R_L = 1.9k\Omega$)
2. High instantaneous common mode rejection voltage
(CM. : TYP. $1kV/\mu s$)
3. Standard dual-in-line package
4. Recognized by UL, file No. E64380

■ Applications

1. Computers, measuring instruments, controllers
2. High speed line receivers high speed logic
3. Switching regulators
4. Signal transmission between circuits of different potentials and impedances

■ Outline Dimensions

(Unit : mm)

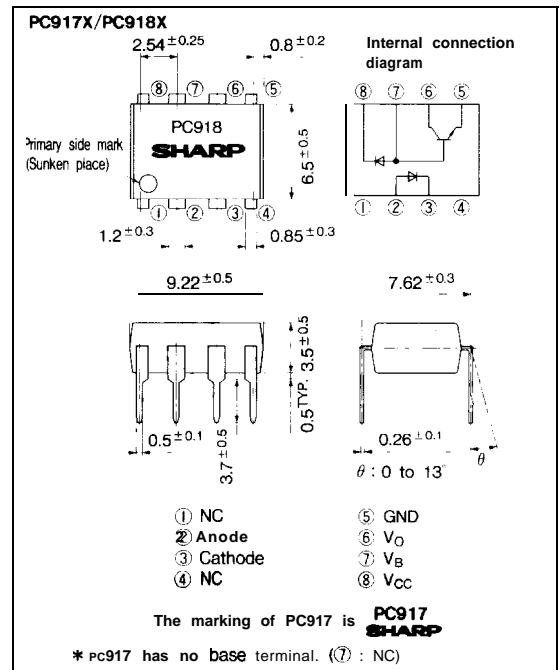

* "OPIC" (Optical IC) is a trademark of the SHARP Corporation
An OPIC consists of a light-detecting element and signal processing circuit integrated onto a single chip.

■ Absolute Maximum Ratings

(Ta = 25°C)

	Parameter	Symbol	Rating	Unit
Input	Forward cur-rent	I_F	25	mA
	Reverse voltage	V_R	5	v
	Power dissipation	P	45	mW
output	Supply voltage	V_{CC}	-0.5 to +15	v
	Output voltage	V_O	-0.5 to +15	V
	*1 Emitter-base voltage	V_{EBO}	5	v
	Output current	I_O	8	mA
	Power dissipation	P_O	100	mW
	*2 Isolation voltage	v.) ."	2 500	V_{rms}
	Operating temperature	T_{opr}	-55 to +100	°C
	Storage temperature	T_{stg}	-55 to +125	°C
	*3 Soldering temperature	T_{sol}	260	°C

*1 Voltage between pin 5 and pin 7 (applies to PC918X)

*2 40 to 60%RH, AC for 1 minute

*3 For 10 seconds

Electro-optical Characteristics

(Unless otherwise specified, $T_a = 0$ to $+70^\circ\text{C}$)

Parameter		Symbol	Conditions	MIN.	TYP.	MAX.	Unit
Input	Forward voltage	V_F	$T_a=25^\circ\text{C}$, $I_F=16\text{mA}$	—	1.7	1.95	v
	Reverse current	I_R	$T_a=25^\circ\text{C}$, $V_R=5\text{V}$	—	—	10	μA
	Terminal capacitance	C_t	$T_a=25^\circ\text{C}$, $V_F=0$, $f=1\text{MHz}$	—	60	250	pF
output	High level output current (1)	$I_{OH(1)}$	$T_a=25^\circ\text{C}$, $I_F=0$, $V_{CC}=V_O=5.5\text{V}$	—	3	500	nA
	High level output current (2)	$I_{OH(2)}$	$T_a=25^\circ\text{C}$, $I_F=0$, $V_{CC}=V_O=15\text{V}$	—	—	1	μA
	High level output current (3)	$I_{OH(3)}$	$I_F=0$, $V_{CC}=V_O=15\text{V}$	—	—	50	μA
	Low level output voltage	V_{OL}	$I_F=16\text{mA}$, $I_O=2.4\text{mA}$, $V_{CC}=4.5\text{V}$	—	—	0.4	v
	Low level supply current	I_{CCL}	$I_F=16\text{mA}$, $V_O=\text{open}$, $V_{CC}=15\text{V}$	—	200	—	μA
	High level SUPPLY current (1)	$I_{CCH(1)}$	$T_a=25^\circ\text{C}$, $I_F=0$, $V_O=\text{open}$ $V_{CC}=15\text{V}$	—	0.02	1	μA
	High level supply current (2)	$I_{CCH(2)}$	$I_F=0$, $V_O=\text{open}$, $V_{CC}=15\text{V}$	—	—	2	μA
Transfer characteristics	Current transfer ratio	CTR	$T_a=25^\circ\text{C}$, $I_F=16\text{mA}$, $V_O=0.4\text{V}$, $V_{CC}=4.5\text{V}$	19	—	—	%
	Isolation resistance	R_{iso}	$T_a=25^\circ\text{C}$, DC500V, 40 to 60%RH	5×10^{10}	10^{11}	—	Ω
	Floating capacitance	C_f	$T_a=25^\circ\text{C}$, $V=0$, $f=1\text{MHz}$	—	0.6	1	pF
	High \rightarrow Low propagation delay time	t_{PHL}	$T_a=25^\circ\text{C}$, $R_L=1.9\text{k}\Omega$ $I_F=16\text{mA}$, $V_{CC}=5\text{V}$	—	0.3	0.8	μs
	Low \rightarrow High propagation delay time	t_{PLH}	$T_a=25^\circ\text{C}$, $R_L=1.9\text{k}\Omega$ $I_F=16\text{mA}$, $V_{CC}=5\text{V}$	—	0.3	1.2	μs
	*Instantaneous common mode rejection voltage "Output: High level"	CM_H	$T_a=25^\circ\text{C}$, $I_F=0$, $R_L=1.9\text{k}\Omega$ $V_{CM}=10\text{Vp-p}$, $V_{CC}=5\text{V}$	—	1 000	—	$\text{V}/\mu\text{s}$
	*Instantaneous common mode rejection voltage "Output: Low level"	CM_L	$T_a=25^\circ\text{C}$, $I_F=16\text{mA}$, $R_L=1.9\text{k}\Omega$ $V_{CM}=10\text{Vp-p}$, $V_{CC}=5\text{V}$	—	-1000	—	$\text{V}/\mu\text{s}$

***4 Test Circuit for Propagation Delay Time (PC918X)**

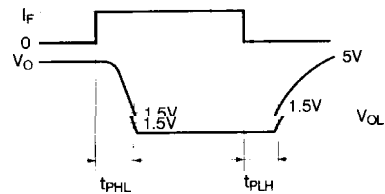
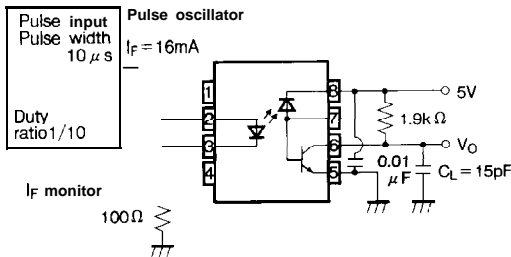

***5 Test Circuit for Instantaneous Common Mode Rejection Voltage (PC918X)**

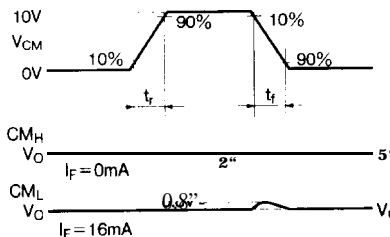
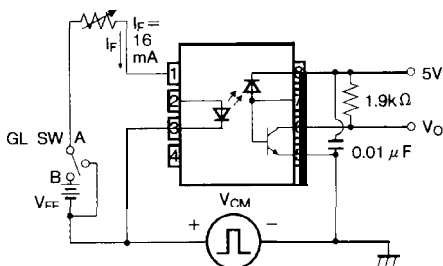

When the switch for infrared light emitting diode sets to A.

When the switch for infrared light emitting diode sets to B.

Fig. 1 Forward Current vs. Ambient Temperature

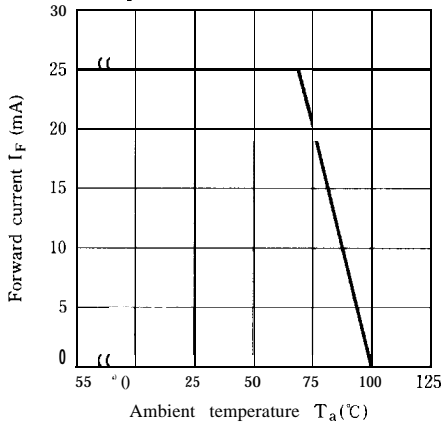

Fig. 2 Power Dissipation vs. Ambient Temperature

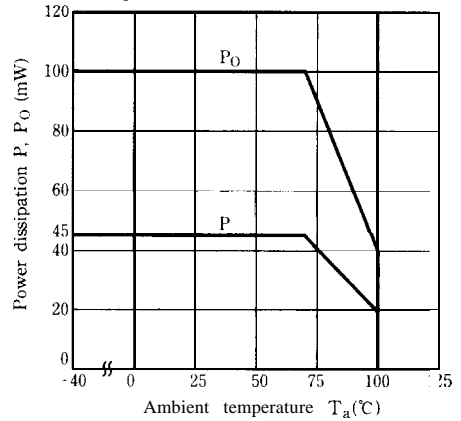

Fig. 3 Forward Current vs. Forward Voltage

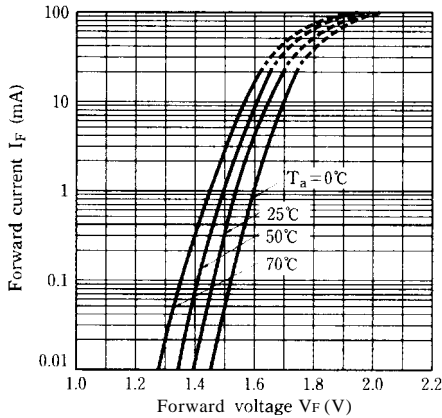

Fig. 4 Output Current vs. Output Voltage

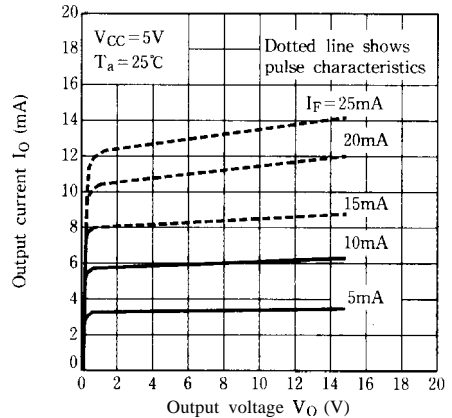

Fig. 5 Relative Current Transfer Ratio vs. Forward Current

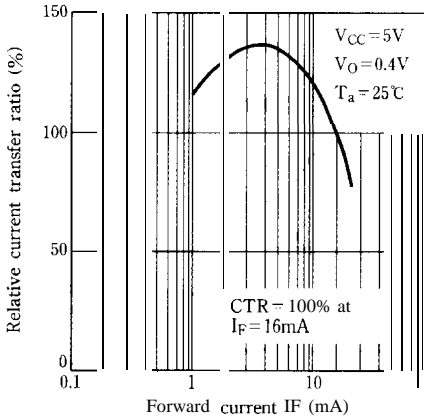

Fig. 6 Relative Current Transfer Ratio vs. Ambient Temperature

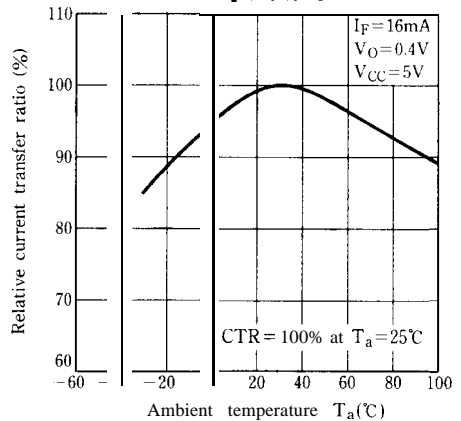

Fig. 7 Propagation Delay Time vs. Ambient Temperature

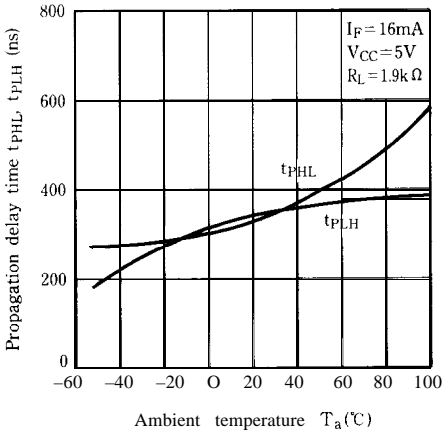

Fig. 8 High Level Output Current vs. Ambient Temperature

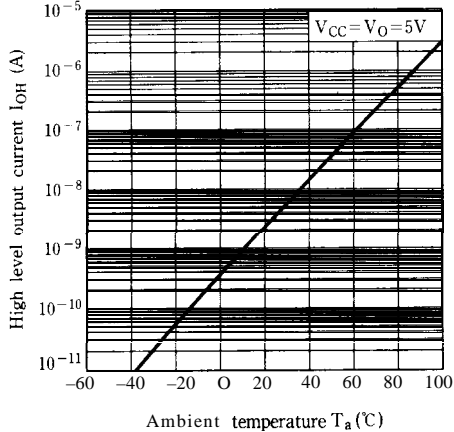
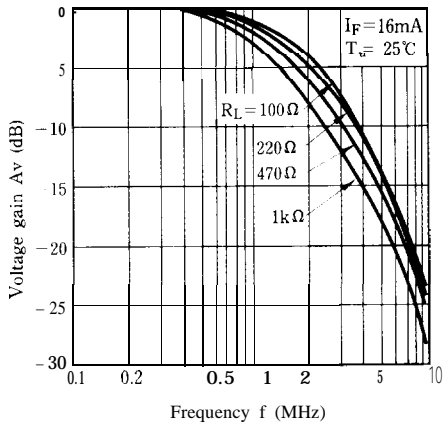
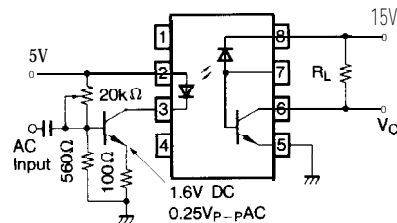

Fig. 9 Frequency Response



Test Circuit for Frequency Response (PC918X)



■ Precautions for USE

- (1) It is recommended that a by-pass capacitor of more than 0.01 μ F is added between V_{CC} and GND near the device in order to stabilize power supply line.
- (2) Transistor of detector side in bipolar configuration is apt to be affected by static electricity for its minute design. When handling them, general counterplan against static electricity should be taken to avoid breakdown of devices or degradation of characteristics.
- (3) As for other general cautions, refer to the chapter "Precautions for Use" (Page 78 to 93).